



US008164096B2

(12) **United States Patent**
Choi et al.

(10) **Patent No.:** **US 8,164,096 B2**
(45) **Date of Patent:** **Apr. 24, 2012**

(54) **ORGANIC LIGHT EMITTING DIODE FLAT PANEL DISPLAY DEVICE HAVING UNIFORM ELECTRICAL CHARACTERISTICS AND METHOD OF MANUFACTURING THE SAME**

(75) Inventors: **Jong-Hyun Choi**, Suwon-si (KR);
Woo-Sik Jun, Suwon-si (KR)

(73) Assignee: **Samsung Mobile Display Co., Ltd.**,
Yongin (KR)

(*) Notice: Subject to any disclaimer, the term of this patent is extended or adjusted under 35 U.S.C. 154(b) by 619 days.

(21) Appl. No.: **12/047,619**

(22) Filed: **Mar. 13, 2008**

(65) **Prior Publication Data**
US 2008/0224129 A1 Sep. 18, 2008

(30) **Foreign Application Priority Data**
Mar. 13, 2007 (KR) 10-2007-0024584

(51) **Int. Cl.**
H01L 27/14 (2006.01)
(52) **U.S. Cl.** **257/72; 257/40; 257/E51.001; 257/59; 257/294; 438/310; 438/335; 438/143**
(58) **Field of Classification Search** **257/59, 257/294, 72, 40; 438/310, 335, 143**
See application file for complete search history.

(56) **References Cited**

U.S. PATENT DOCUMENTS

2003/0102478 A1* 6/2003 Joo et al. 257/72
2007/0102699 A1* 5/2007 Lee et al. 257/40

FOREIGN PATENT DOCUMENTS

JP	8-139330	5/1996
JP	2003-8027	1/2003
KR	2001-66251	7/2001
KR	2004-70979	8/2004
KR	2006-1711	1/2006
KR	2006-12850	2/2006
KR	2006-17424	2/2006
KR	10-776481	11/2007

OTHER PUBLICATIONS

H.K. Chung, K.Y. Lee; Alternative approach to Large size AMOLED HDTV; 2005; SID 05 Digest; 16.1 p. 956-959.*
U.S. Appl. No. 12/048,662, filed Mar. 14, 2008, Kyoung-Bo Kim, Samsung SDI Co., Ltd.
Korean Notice of Allowability issued on Jan. 28, 2008 in the corresponding Korean Patent Application No. 2007-24584.
Notice of Allowance issued in Korean Patent Application No. 2007-26202 on Jul. 29, 2008.
Notice of Allowance issued in Korean Patent Application No. 2007-27141 on Jul. 29, 2008.

* cited by examiner

Primary Examiner — Marcos D. Pizarro
Assistant Examiner — Eva Yan Montalvo

(74) *Attorney, Agent, or Firm* — H.C. Park & Associates, PLC

(57) **ABSTRACT**

A flat panel display device, more particularly, an Organic Light Emitting Diode (OLED) display device having uniform electrical characteristics and a method of fabricating the same include: a thin film transistor of which a semiconductor layer including a source, a drain, and a channel region formed in a super grain silicon (SGS) crystallization growth region; a capacitor formed in an SGS crystallization seed region; and an OLED electrically connected to the thin film transistor. Further, a length of the channel region of the silicon layer is parallel with the growth direction in the SGS growth region to improve the electrical properties thereof.

14 Claims, 10 Drawing Sheets

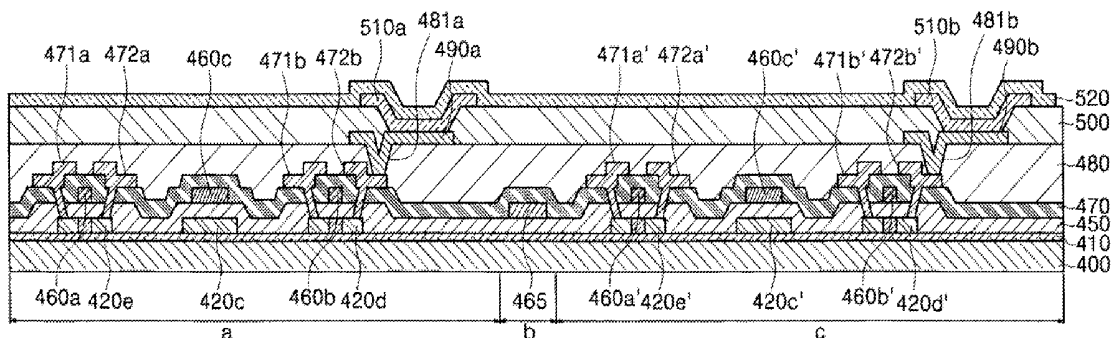

FIG. 1A

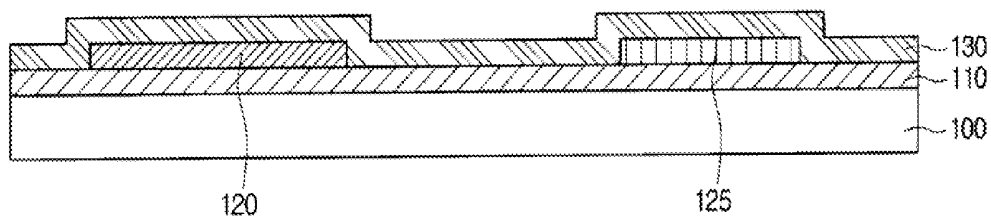

FIG. 1B

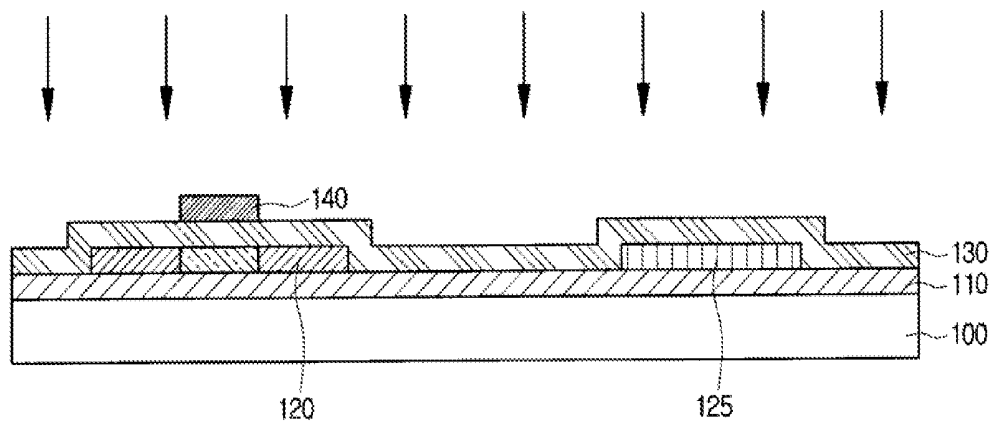

FIG. 1C

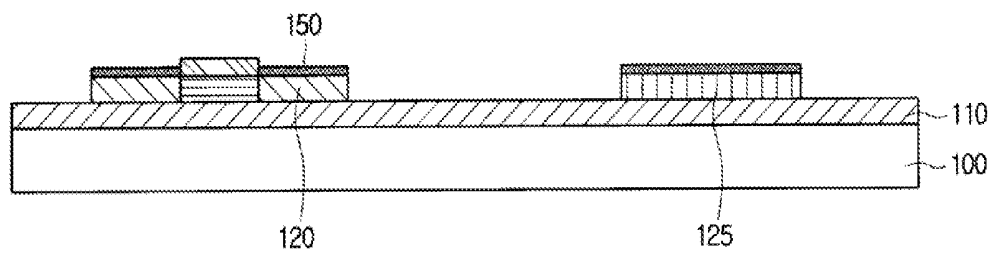

FIG. 1D

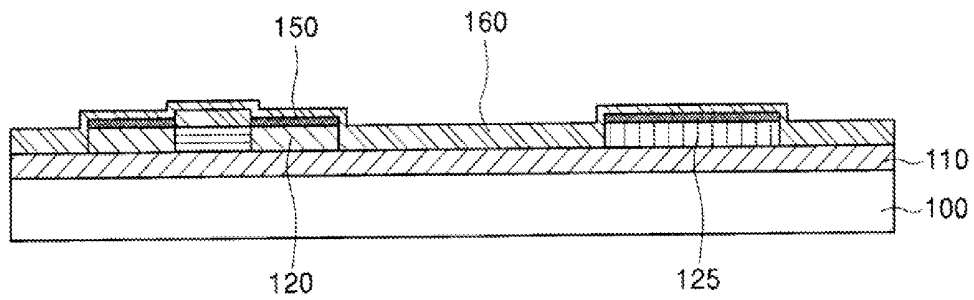

FIG. 1E

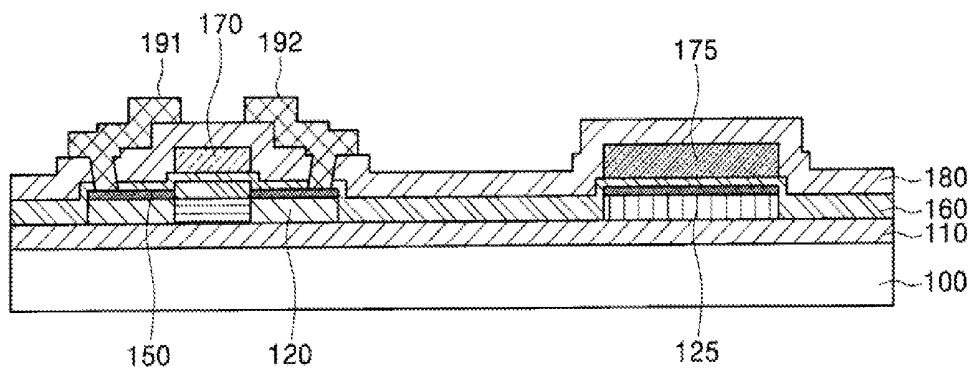

FIG. 2A

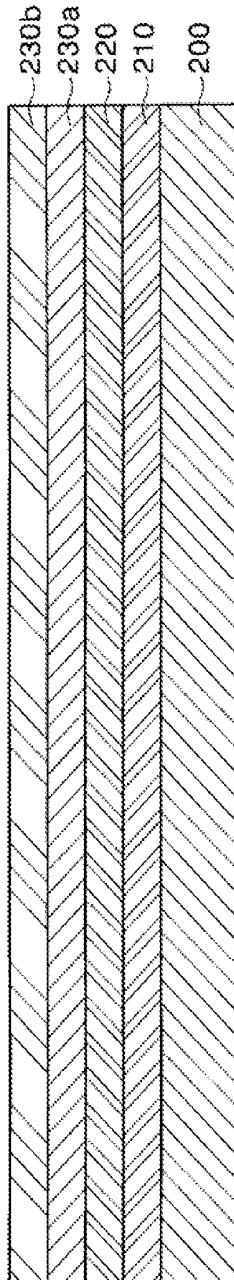

FIG. 2B

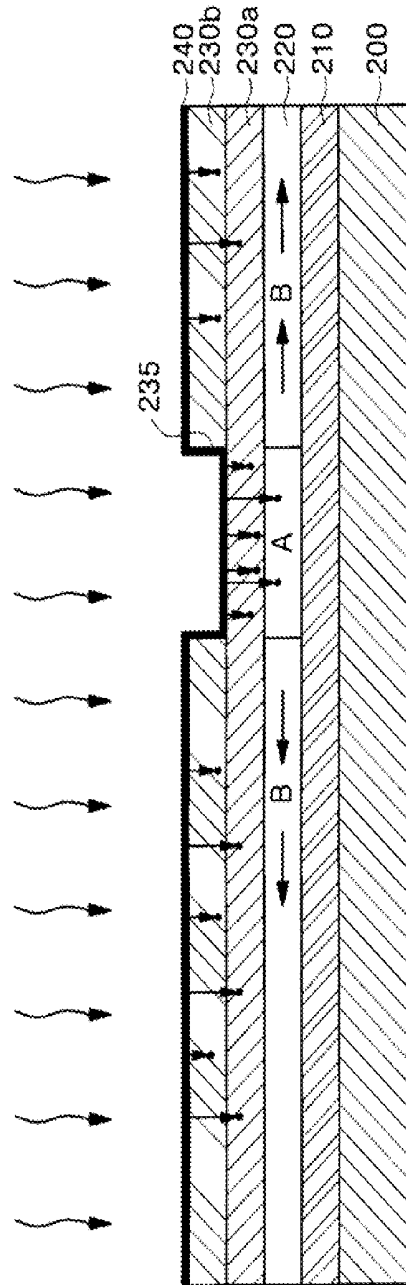

FIG. 2C

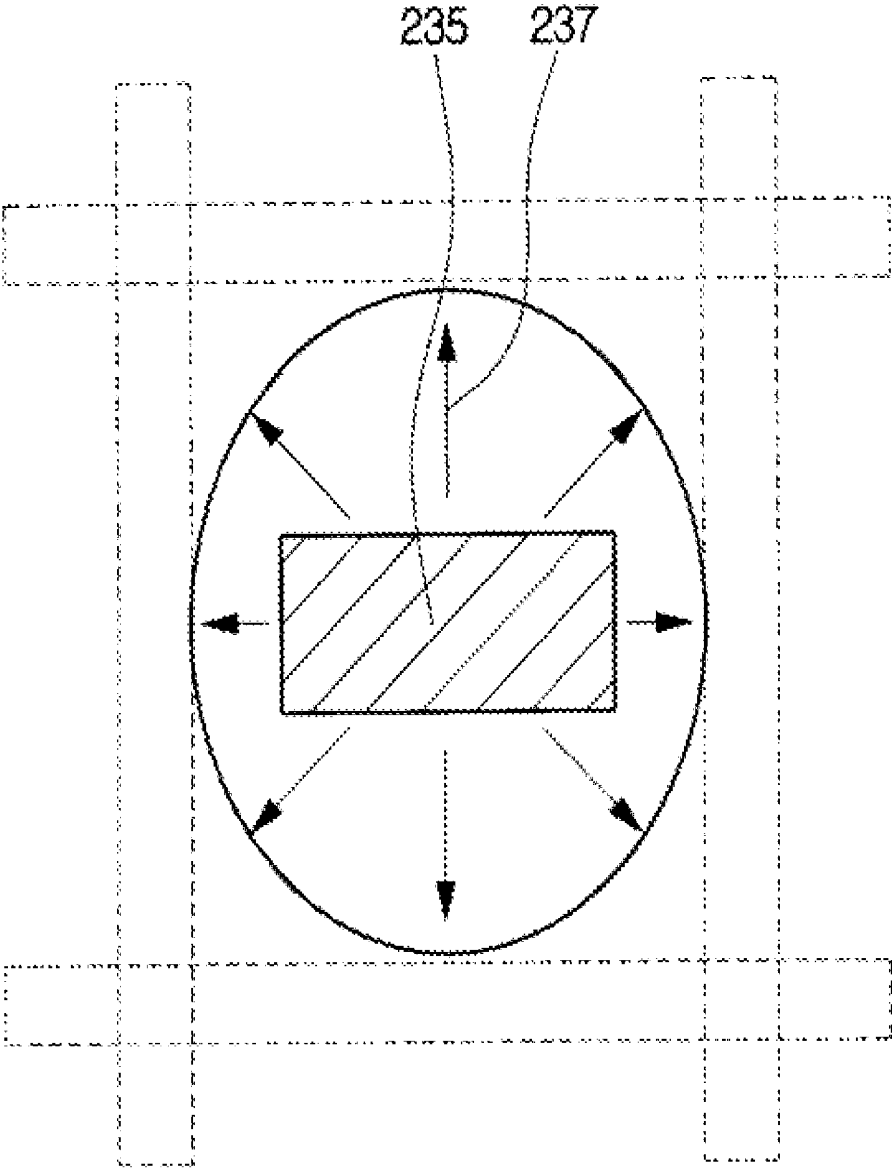

FIG. 2D

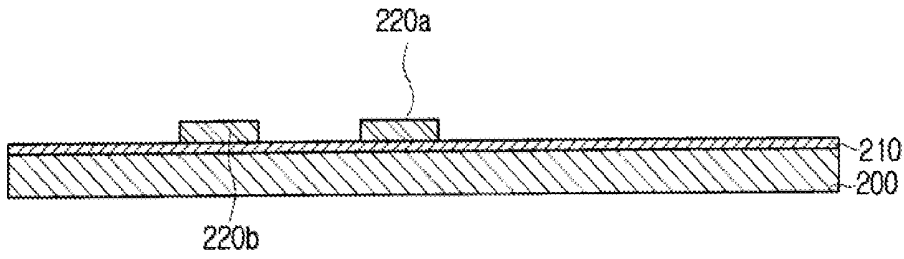

FIG. 2E

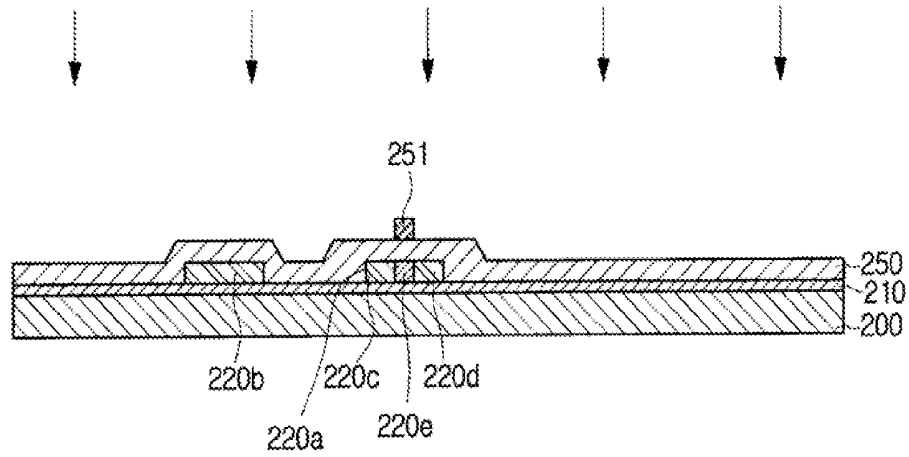

FIG. 2F

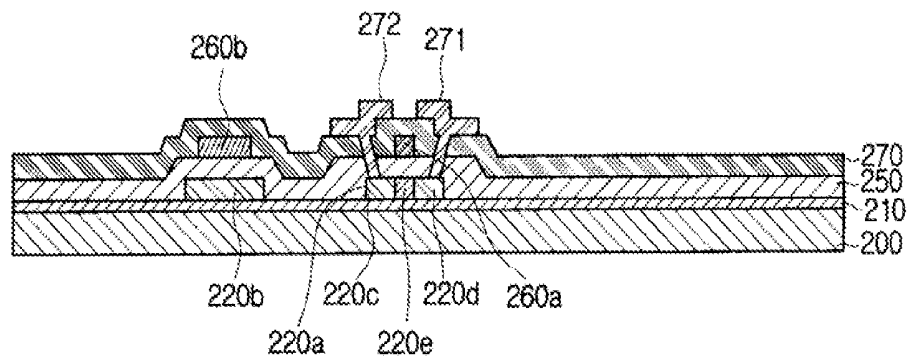

FIG. 2G

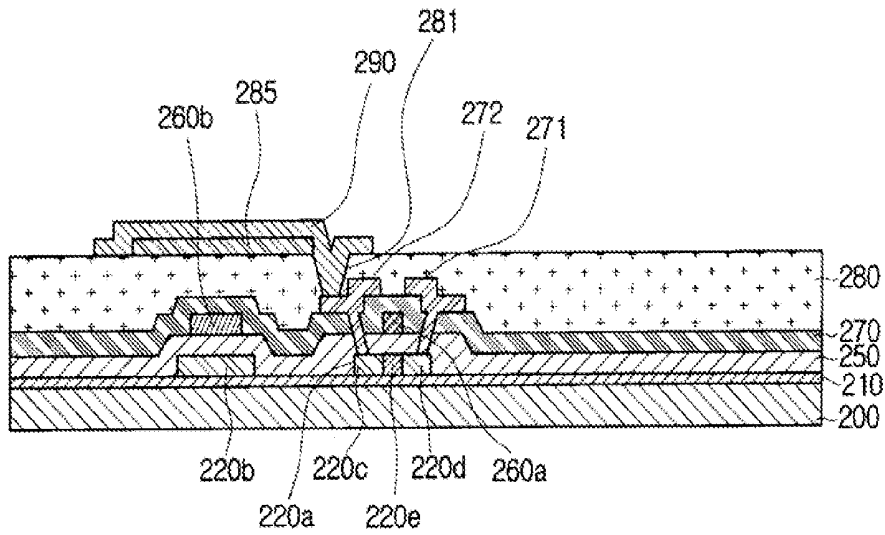

FIG. 2H

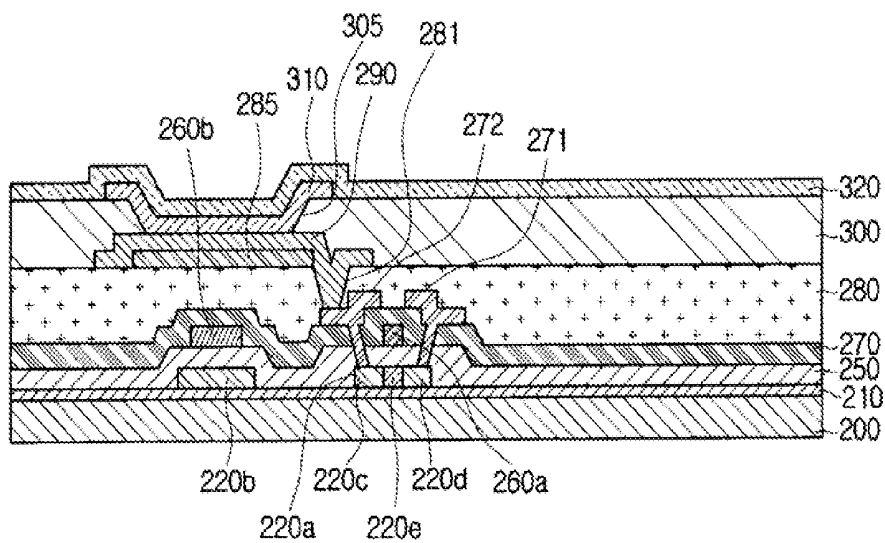

FIG. 3

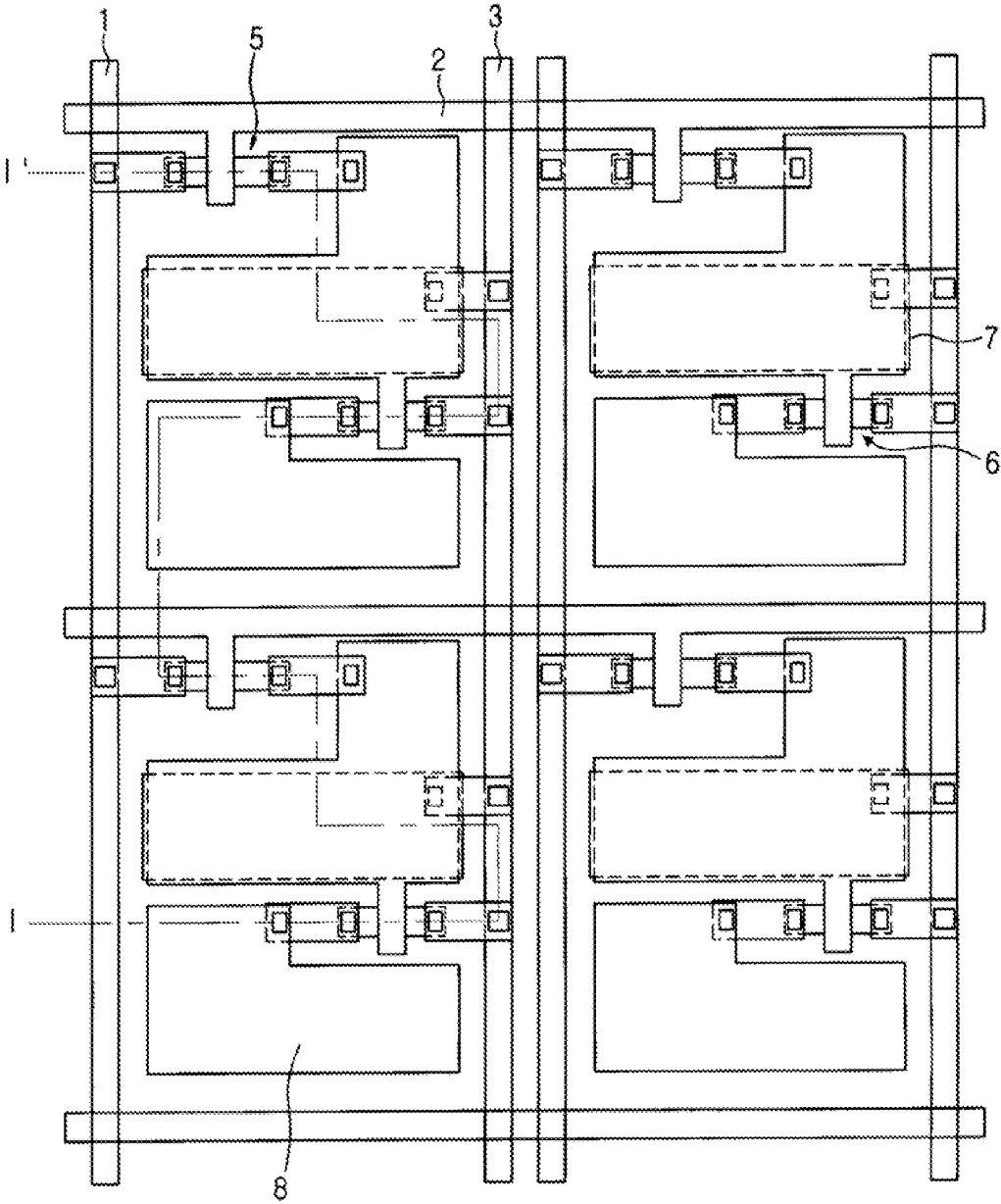

FIG. 4A

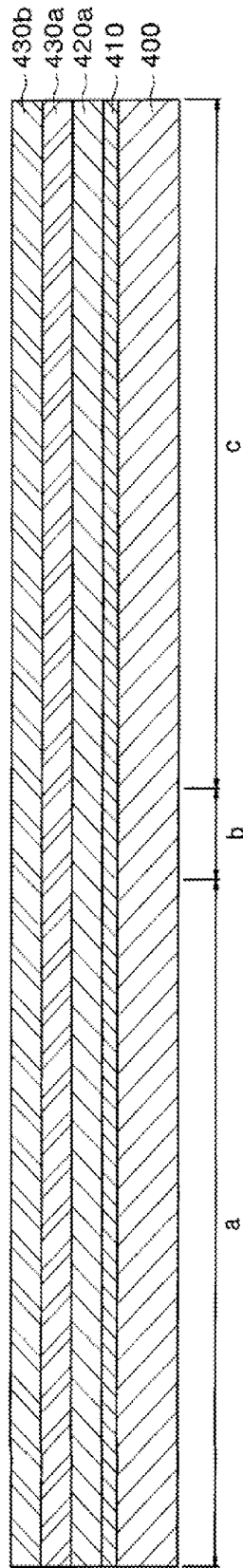

FIG. 4B

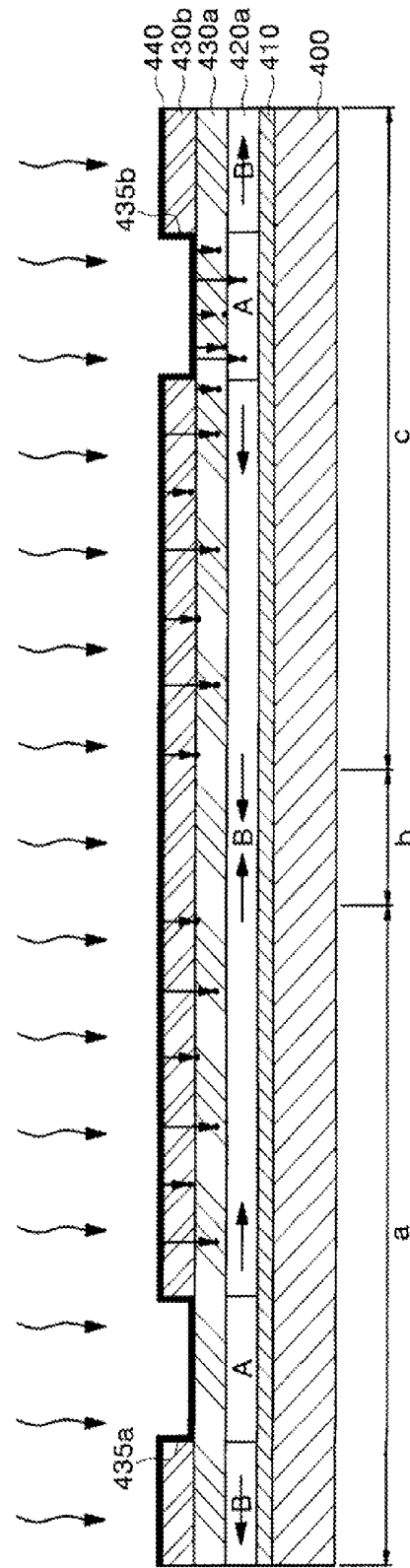

FIG. 4C

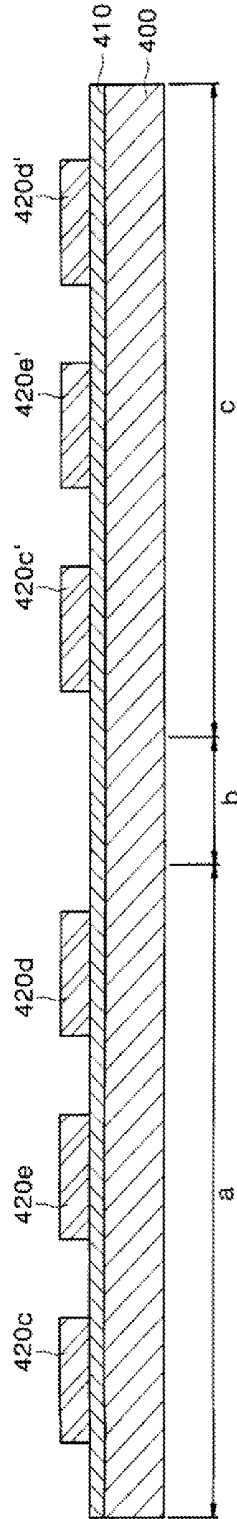

FIG. 4D

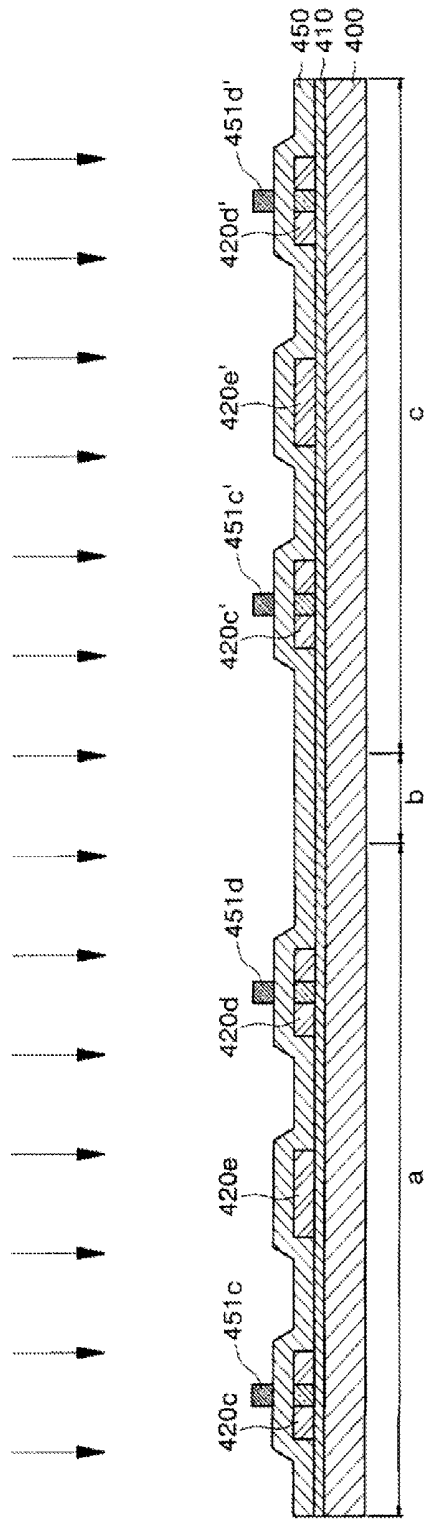

FIG. 4E

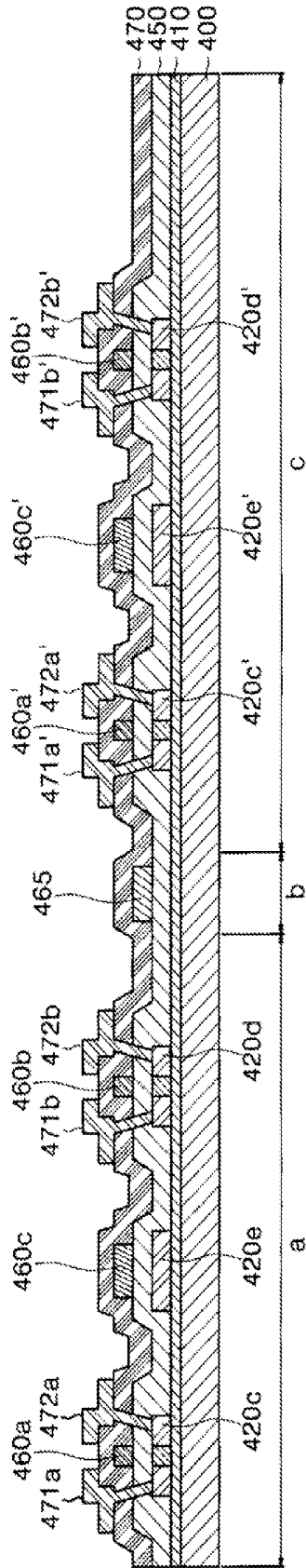
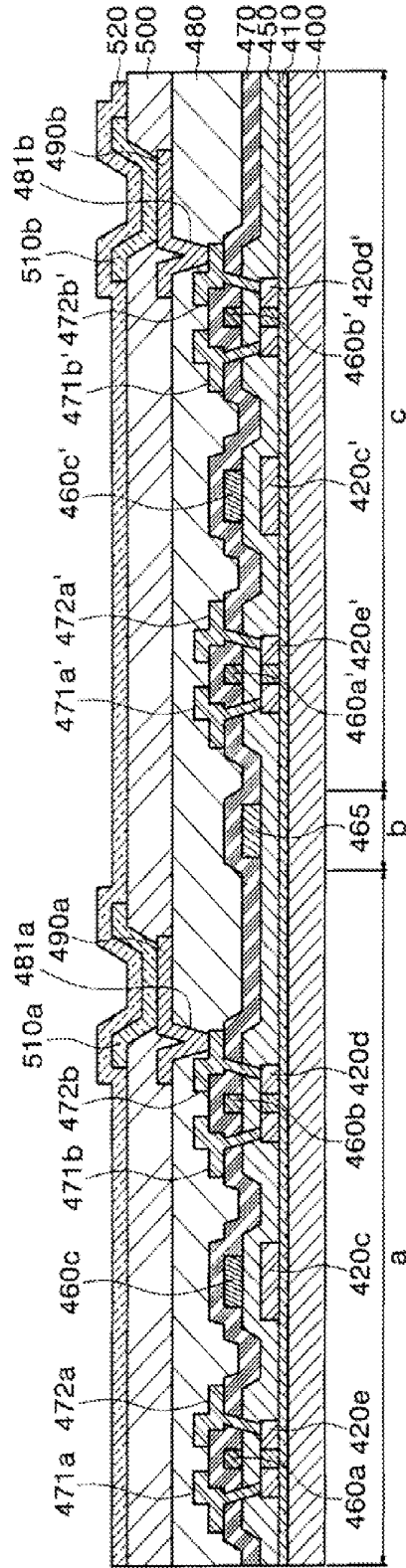

FIG. 4F



**ORGANIC LIGHT EMITTING DIODE FLAT
PANEL DISPLAY DEVICE HAVING
UNIFORM ELECTRICAL
CHARACTERISTICS AND METHOD OF
MANUFACTURING THE SAME**

CROSS-REFERENCE TO RELATED
APPLICATIONS

This application claims the benefit of Korean Patent Application No. 2007-24584, filed Mar. 13, 2007, in the Korean Intellectual Property Office, the disclosure of which is hereby incorporated herein by reference.

BACKGROUND OF THE INVENTION

1. Field of the Invention

Aspects of the present invention relate to a Flat panel display device and a method of manufacturing the same, and more particularly, an OLED display device having uniform electrical characteristics and a method of manufacturing the same.

2. Description of the Related Art

Flat panel display devices such as Liquid Crystal Display (LCD) devices, OLED display devices or Plasma Display Panels (PDPs) have recently attracted attention as such displays overcome disadvantages of conventional display devices, such as Cathode Ray Tubes (CRTs). Here, among the flat panel display devices, OLED display devices and LCD devices include a thin film transistor as a switching or driving device and a capacitor to store an external signal in connection with the thin film transistor and to provide the stored external signal until the next signal period.

FIG. 1A to 1E are cross-sectional views of a conventional OLED display device. First, referring to FIG. 1A, a buffer layer 110 is formed on a substrate 100, which is formed of plastic or glass, and an amorphous silicon layer is formed on the buffer layer 110, and the amorphous silicon layer is patterned to form a semiconductor layer 120 and a first capacitor electrode 125. Subsequently, an insulating layer 130 is formed on the substrate 100, i.e., the insulating layer 130 is formed to cover the patterned semiconductor layer 120, the first capacitor electrode 125, and the buffer layer 110.

Referring to FIG. 1B, a photoresist pattern 140 is formed in a region corresponding to the semiconductor layer 120. An impurity implantation process is performed using the photoresist pattern 140 as a mask, thereby defining source, drain, and channel regions, and implanting impurities into the first capacitor electrode 125.

Referring to FIG. 1C, the insulating layer 130 is etched to form an insulating layer pattern corresponding to the channel region of the semiconductor layer 120, and a metal catalyst layer 150 is formed on the substrate and then removed from regions other than the regions corresponding to the source and drain regions of the semiconductor layer 120 and the first electrode 125.

Referring to FIG. 1D, a gate insulating layer 160 is formed on the substrate 100, and the substrate is annealed to crystallize the source and drain regions and the first capacitor electrode 125 using a metal induced crystallization (MIC) technique and to crystallize the channel region using a metal induced lateral crystallization (MILC) technique.

Referring to FIG. 1E, a gate electrode 170 is formed to correspond to a region of the semiconductor layer 120 (the gate electrode 170 corresponds to the channel region of the semiconductor layer 120), and a second capacitor electrode 175 is formed to correspond to the first capacitor electrode

125. Then, an interlayer insulating layer 180 is formed on the substrate 100, and source and drain electrodes 191 and 192 are formed on the interlayer insulating layer 180 and extend through the interlayer insulating layer 180 and the gate insulating layer 160 to connect to the metal catalyst layer 150 on the source and drain regions of the semiconductor layer 120, thereby completing a thin film transistor and a capacitor. Moreover, not illustrated in FIG. 1E, a first electrode, an organic layer and a second electrode are formed, thereby completing a conventional OLED display device.

However, as described above, when the semiconductor layer is crystallized by the MIC/MILC techniques, MILC crystals are faced in the channel region, thereby generating a MILC front or grain boundary, that is, an uncrystallized region, which results in deterioration of charge mobility and device's characteristics.

SUMMARY OF THE INVENTION

Aspects of the present invention provide a flat panel display device having uniform electrical characteristics and a method manufacturing the same, more particularly, an Organic Light Emitting Diode (OLED) display device having uniform electrical characteristics and a method of manufacturing the same.

According to an aspect of the present invention, a flat panel display device comprising: a thin film transistor disposed on a substrate, the thin film transistor comprising a semiconductor layer formed in a super grain silicon (SGS) crystallization growth region of a crystalline silicon layer disposed on the substrate and having source and drain regions and a channel region, a gate electrode formed to correspond to a partial region of the semiconductor layer, a gate insulating layer to insulate the semiconductor layer from the gate electrode, and source and drain electrode electrically connected to the source and drain regions of the semiconductor layer; a capacitor comprising a first capacitor electrode spaced apart from the thin film transistor on the substrate and formed in an SGS crystallization seed region of the crystalline silicon layer disposed on the substrate, a second capacitor electrode formed on the gate insulating layer, and, the gate insulating layer to insulate the first capacitor electrode from the second capacitor electrode, and a first electrode of a display electrically connected to one of the source or drain electrodes of the thin film transistor.

According to another aspect of the present invention, a method of fabricating a flat panel display device comprising: preparing a substrate; forming an amorphous silicon layer on the substrate; forming first and second capping layers on the amorphous silicon layer; etching the second capping layer to expose a part of the first capping layer; forming a metal catalyst layer to cover the second capping layer and the exposed portion of the first capping layer; annealing the substrate to crystallize the amorphous silicon layer under the exposed first capping layer to form a super grain silicon (SGS) crystallization seed region, and to crystallize the amorphous silicon layer from the SGS crystallization seed region to an SGS crystallization growth region; removing the first capping layer, the second capping layer, and the metal catalyst layer; patterning the crystallized silicon layer to form a first capacitor electrode in the SGS crystallization seed region and to form a semiconductor layer in the SGS crystallization growth region; forming a gate insulating layer to cover the semiconductor layer and the first capacitor electrode; forming a gate electrode on the gate insulating layer in a region corresponding to a partial region of the semiconductor layer; forming a second capacitor electrode on the gate insulating

layer in a region corresponding to the first capacitor electrode; forming source and drain electrodes electrically connected to the semiconductor layer; and forming a first electrode of a display to be electrically connected to one of the source or drain electrodes.

According to still another aspect of the present invention, a flat panel display device comprising: a substrate having a first unit pixel region, a second unit pixel region, and an interconnection region disposed therebetween; thin film transistors comprising: semiconductor layers disposed on the first and second unit pixel regions of the substrate, and including source, drain, and channel regions formed in super grain silicon (SGS) crystallization growth regions of a crystalline silicon layer disposed on the substrate, gate electrodes formed to correspond to partial regions of the semiconductor layers, a gate insulating layer to insulate the semiconductor layers from the gate electrodes, and source and drain electrodes electrically connected respectively to the source and drain regions of the semiconductor layer; capacitors comprising: first capacitor electrodes disposed about the interconnection region on the first and second unit pixel regions, and formed in SGS crystallization seed regions of the crystalline silicon layer disposed on the substrate, the gate insulating layer disposed on the first capacitor electrodes, and second capacitor electrodes disposed on the gate insulating layer; and first electrodes of a display electrically connected to one of the source and drain electrodes of the thin film transistors, respectively.

According to yet another aspect of the present invention, a method of fabricating a flat panel display device comprising: preparing a substrate having a first unit pixel region, a second unit pixel region, and an interconnection region disposed therebetween; forming an amorphous silicon layer on the substrate; forming first and second capping layers on the amorphous silicon layer; etching parts of the second capping layer in regions disposed about the interconnection region to expose parts of the first capping layer; forming a metal catalyst layer to cover the second capping layer and the exposed parts of the first capping layer; annealing the substrate to crystallize the amorphous silicon layer under the exposed first capping layer to form super grain silicon (SGS) crystallization seed regions, and to crystallize the amorphous silicon layer from the SGS crystallization seed regions to SGS crystallization growth regions; removing the first capping layer, the second capping layer, and the metal catalyst layer; patterning the crystallized silicon layer to form first capacitor electrodes in the SGS crystallization seed regions and to form semiconductor layers in the SGS crystallization growth regions; forming a gate insulating layer to insulate the semiconductor layers from the gate electrodes; forming gate electrodes on the gate insulating layer in regions corresponding to the semiconductor layers; forming second capacitor electrodes on the gate insulating layer in regions corresponding to the first capacitor electrodes; forming source and drain electrodes electrically connected to the semiconductor layer; and forming first electrodes of a display to be electrically connected respectively with one of the source or drain electrodes.

Additional aspects and/or advantages of the invention will be set forth in part in the description which follows and, in part, will be obvious from the description, or may be learned by practice of the invention.

BRIEF DESCRIPTION OF THE DRAWINGS

These and/or other aspects and advantages of the invention will become apparent and more readily appreciated from the

following description of the embodiments, taken in conjunction with the accompanying drawings of which:

FIGS. 1A to 1E are cross-sectional views of a conventional Organic Light Emitting Diode (OLED) display device;

FIGS. 2A, 2B, and 2D to 2H are cross-sectional views and FIG. 2C is a plan view of an OLED display device according to an exemplary embodiment of the present invention;

FIG. 3 is a plan view of an OLED display device according to an exemplary embodiment of the present invention; and

FIGS. 4A to 4F are cross-sectional views of the OLED display device taken along line I-I' of FIG. 3.

DETAILED DESCRIPTION OF THE EMBODIMENTS

Reference will now be made in detail to the present embodiments of the present invention, examples of which are illustrated in the accompanying drawings, wherein like reference numerals refer to the like elements throughout. The embodiments are described below in order to explain the aspects of the present invention by referring to the figures. It will be understood that when an element or layer is referred to as being "disposed on" or "formed on" another element or layer, it may be directly disposed or formed on the other element or layer, or intervening elements or layers may be present. Other words used to describe the relationship between elements should be interpreted in a like fashion (e.g., "between" versus "directly between", "adjacent" versus "directly adjacent", etc.).

FIGS. 2A, 2B, and 2D to 2H are cross-sectional views and FIG. 2C is a plan view of an Organic Light Emitting Diode (OLED) display device according to an exemplary embodiment of the present invention. Referring to FIG. 2A, a substrate **200** is provided, which is formed of plastic, conductive material or transparent glass. A buffer layer **210** is formed on the substrate **200**. The buffer layer **210** may be formed of a silicon oxide layer, a silicon nitride layer or a double layer thereof and formed by a Chemical Vapor Deposition (CVD) or Physical Vapor Deposition (PVD) technique. Here, the buffer layer **210** prevents diffusion of moisture or impurities generated from the substrate **200** and/or facilitates crystallization of an amorphous silicon layer by controlling a heat transfer rate during crystallization.

An amorphous silicon layer **220** is formed on the entire surface of the substrate **200**. The amorphous silicon layer **220** may be formed by a PVD technique, such as sputtering, or a CVD technique, such as Plasma Enhanced CVD (PECVD) or Low Pressure CVD (LPCVD). Also, while or after forming the amorphous silicon layer **220**, a hydrogen concentration may be reduced by dehydrogenation.

Then, a first capping layer **230a** and a second capping layer **230b** are formed on the entire surface of the substrate **200**. The capping layers may be formed of a silicon nitride layer through which a metal catalyst (to be formed in a subsequent process) can be diffused by annealing, or formed of a combination of a silicon nitride layer and a silicon oxide layer. Also, the capping layers may be formed to a thickness of 1 to 2000 Å using a CVD or PVD technique.

Referring to FIG. 2B, a partial region of the second capping region **230b** corresponding to a region in which the amorphous silicon layer **220** will be formed into a first capacitor electrode is etched, thereby forming an opening **235**.

After that, metal catalysts are deposited on the entire surface of the substrate **200**, thereby forming a metal catalyst layer **240**. Here, the metal catalyst may be one selected from the group consisting of nickel (Ni), palladium (Pd), titanium (Ti), silver (Ag), gold (Au), aluminum (Al), tin (Sn), anti-

mony (Sb), copper (Cu), cobalt (Co), molybdenum (Mo), terbium (Tb), ruthenium (Ru), rhodium (Rh), cadmium (Cd) and platinum (Pt), and preferably Ni. Here, the metal catalyst layer **240** is formed at a surface density of 10^{11} to 10^{15} atoms/cm². If the surface density is less than 10^{11} atoms/cm², the amorphous silicon layer may be difficult to crystallize into a polycrystalline silicon layer because of a small amount of seeds that is, cores of crystallization, (i.e., the metal catalysts will not sufficiently seed the crystallization of the silicon layer into a polycrystalline silicon layer). If the surface density is more than 10^{15} atoms/cm², grains of the polycrystalline silicon layer may become smaller because of a large amount of the metal catalysts diffused into the amorphous silicon layer.

Subsequently, the substrate **200** having the buffer layer **210**, the amorphous silicon layer **220**, the first capping layer **230a**, the second capping layer **230b**, and the metal catalyst layer **240** is annealed, thereby moving some of the metal catalysts of the metal catalyst layer **240** to the amorphous silicon layer **220**. That is, only a very small amount of the metal catalysts diffused through the first capping layer **230a** by annealing are diffused into the amorphous silicon layer **220**, and most of the metal catalysts cannot reach the amorphous silicon layer **220** or cannot pass through the first and second capping layers **230a** and **230b**.

Accordingly, the amount of the metal catalysts reaching the amorphous silicon layer **220** is determined by the diffusion blocking abilities of the first and second capping layers **230a** and **230b**, wherein the diffusion blocking ability of the first and second capping layers **230a** and **230b** may be related to the thickness of the first and second capping layers **230a** and **230b**. That is, as the first and second capping layers **230a** and **230b** increase in thickness, the amount of diffused metal catalysts becomes smaller, thereby increasing the size of the grain. However, as the first and second capping layers **230a** and **230b** decrease in thickness, the amount of diffused metal catalysts becomes larger, thereby decreasing the size of the grain.

Here, the annealing process is performed in a range from 200 to 900° C. for several seconds to hours in order to diffuse the metal catalysts, which may use one or a combination of a furnace process, a rapid thermal annealing (RTA) process, a UV process, and a laser process.

Accordingly, the metal catalyst diffused into the amorphous silicon layer **220** through the first capping layer **230a** is combined with silicon of the amorphous silicon layer **220** so as to form metal silicide, and the metal silicide forms a seed, i.e., a core of crystallization, thereby crystallizing the amorphous silicon layer **220** into the polycrystalline silicon layer.

As described above, first and second capping layers **230a** and **230b** are formed on the amorphous silicon layer **220**, and the metal catalyst layer **240** is formed on the first and second capping layers **230a** and **230b** and then annealed to be diffused, thereby crystallizing the amorphous silicon layer **220** into a polycrystalline silicon layer, which is called a Super Grain Silicon (SGS) crystallization technique. That is, region A illustrated in FIG. 2B becomes an SGS crystallization seed region A having metal silicide seeds formed by combining the metal catalyst diffused into the amorphous silicon layer **220** through the first capping layer **230a** with the silicon. Region B becomes an SGS crystallization growth region B in which the metal catalyst seeds rarely exist because the metal catalyst cannot diffuse through the first and second capping layers **230a** and **230b** into the amorphous silicon layer **220**, and crystals are grown from the SGS crystallization seed region A into the polycrystalline silicon layer into the SGS crystallization growth region B.

To be more specific, referring to FIG. 2C, a unit pixel region is illustrated. In an opening **235** of the unit pixel, the SGS crystallization seed region A (as in FIG. 2B), is formed, and the SGS crystallization growth region B (as in FIG. 2B) is a peripheral region of the SGS crystallization seed region A. Polycrystalline silicon is crystallized from the SGS crystallization seed region A to the SGS crystallization growth region B so as to crystallize the amorphous silicon layer **220** into the polycrystalline silicon. As a result, at an edge of the unit pixel in which a metal interconnection will be formed, SGS crystallization crystals of different unit pixels are faced, thereby generating a grain boundary. Thus, a uniform polycrystalline silicon layer without a grain boundary is formed in each pixel unit, which advantageously forms a semiconductor layer having no grain boundary in any unit pixel except the SGS crystallization seed region.

Referring to FIG. 2D, after removing the first capping layer **230a**, the second capping layer **230b**, and the metal catalyst layer **240**, the crystallized polycrystalline silicon layer is patterned to form a semiconductor layer **220a** and a first capacitor electrode **220b**. Here, the first capacitor electrode **220b** is formed in the SGS crystallization seed region A formed in the previous crystallization process. The capacitor has better characteristics as the capacitor electrode is closer to metal. The SGS crystallization seed region A includes the metal silicide, so it is preferable the first capacitor electrode **220b** is formed by using the SGS crystallization seed region but is not limited thereto. Also, the semiconductor layer **220a** is formed in the SGS crystallization growth region B formed in the previous crystallization process. It may be preferable that a length direction of a channel region of the semiconductor layer **220a** is formed parallel to the SGS crystallization growth direction. That is, since the length direction of the channel region of the semiconductor layer **220a** is parallel to the SGS crystallization direction **237** of FIG. 2C, the channel region may be formed without a grain boundary, which results in improvement of electrical characteristics of the device without deterioration of charge mobility.

Then, referring to FIG. 2E, a gate insulating layer **250** is formed on the entire surface of the substrate **200**, i.e., the gate insulating layer **250** is formed on the substrate **200** to cover the semiconductor layer **220a**, the first capacitor electrode **220b**, and the buffer layer **210**. The gate insulating layer **250** may be formed of a silicon oxide layer, a silicon nitride layer, or a combination thereof. The gate insulating layer **250** is disposed between the semiconductor layer **220a** and a gate electrode to be formed layer, thereby the gate insulating layer **250** insulates the semiconductor layer **220a** from the gate electrode. Also, the gate insulating layer **250** may be disposed between the first capacitor electrode **220b** and a second capacitor electrode to be formed later, thereby controlling the capacitance of a capacitor according to the thickness of the gate insulating layer **250**. Since capacitance is inversely proportional to the thickness of an insulating layer of a capacitor, the gate insulating layer **250** is preferably formed thinly.

After that, a photoresist is coated on the substrate **200** by, for example, spin coating, and exposed and developed to form a photoresist pattern **251** on a partial region corresponding to the semiconductor layer **220a**. It may be preferable that the photoresist pattern **251** is formed on a region corresponding to the middle of the semiconductor layer **220a** because the region corresponding to the photoresist pattern **251** will be defined as a channel region of the semiconductor layer **220a** later.

Subsequently, impurities are implanted into the entire surface of the substrate **200** having the photoresist pattern **251** using the photoresist pattern **251** as a mask. Thereby, source

and drain regions **220c** and **220d** and a channel region **220e** are defined in the semiconductor layer **220a**. Here, the source and drain regions **220c** and **220d** are implanted with impurities, but the channel **220e** is not implanted with impurities due to the photoresist pattern **251**.

The first capacitor electrode **220b** is also implanted with impurities to obtain characteristics close to a conductor by implanting impurities into the polycrystalline silicon, i.e., semiconductor, because a capacitor has better characteristics as the capacitor electrode is closer to a conductor.

Referring to FIG. 2F, after the impurity implantation process, the photoresist pattern **251** is removed, and a conductive material simultaneously forming a gate electrode and a second capacitor electrode is deposited on the entire surface of the substrate **200**. Then, the conductive material is patterned to correspond to a partial region of the semiconductor layer **220a** and the first capacitor electrode **220b**, thereby forming the gate electrode **260a** and the second capacitor electrode **260b**, and thus a capacitor is completed. Here, the second capacitor electrode **260b** may be formed of the same material as the gate electrode **260a** or source and drain electrodes **271** and **272**.

After that, an interlayer insulating layer **270** is formed on the entire surface of the substrate **200**, the interlayer insulating layer **270** and the gate insulating layer **250** are partially etched to expose surfaces of the source and drain regions **220c** and **220d** of the semiconductor layer **220a**, and then source and drain electrode materials are deposited and patterned to form source and drain electrodes **271** and **272**. Thus, a thin film transistor is completed.

As such, by using the SGS crystallization technique, no grain boundary is formed in the channel region of the semiconductor layer, thereby improving charge mobility and electrical characteristics of the thin film transistor. The thin film transistor according to the exemplary embodiment of the present invention is not limited to an Organic Light Emitting Diode (OLED) display device to be described later, and may be employed in other display devices, such as Liquid Crystal Display (LCD) devices.

Then, referring to FIG. 2G, a planarization layer **280** is formed on the entire surface of the substrate **200**. The planarization layer **280** may be formed of an organic layer, an inorganic layer, or a combination thereof. If the planarization layer **280** is an inorganic layer, Spin On Glass (SOG) may be used, whereas if the planarization layer **280** is an organic layer, acryl series resin, polyimide series resin, or benzocyclobutene (BCB) may be used. Also, the planarization layer **280** includes a hole **281** exposing one of the source and drain electrodes **271** and **272**.

A first electrode **290** is formed on the planarization layer **280**. The first electrode **290** may include a reflective layer **285** formed on the planarization layer **280**. The first electrode **290** is in contact with one of the exposed source and drain electrodes **271** and **272** through the hole **281**, and extends onto the planarization layer **280**. The first electrode **290** may be formed of indium tin oxide (ITO) or indium zinc oxide (IZO).

Referring to FIG. 2H, a pixel defining layer **300** is formed on the entire surface of the substrate **200** including the first electrode **290**, and formed to have a sufficient thickness to cover the first electrode **290**. The pixel defining layer **300** may be an organic layer or an inorganic layer, and preferably an organic layer. More preferably, the pixel defining layer **300** is formed of one selected from the group consisting of BCB, an acryl series polymer, and polyimide. The pixel defining layer **300** may be evenly formed on the entire surface of the sub-

strate **200** because of its excellent flowability. The pixel defining layer **300** is etched to form an opening **305** to expose the first electrode **290**.

Then, an organic layer **310** is formed on the first electrode **290** exposed through the opening **305**. The organic layer **310** includes at least an emission layer, and may further include at least one of a hole injection layer, a hole transport layer, an electron transport layer, and an electron injection layer. The organic layer **310** may include red (R), green (G), and/or blue (B) emission layers to display full colors. The organic layer **310** may be formed of an organic material displaying white, or may be formed of emission layers realizing white by stacking R, G and B emission layers.

Finally, a second electrode **320** is formed on the entire surface of the substrate **200**. The second electrode **320** may be formed as a transmissive electrode. The second electrode **320** may be formed of magnesium (Mg), Ag, Al, calcium (Ca), and alloys thereof having a low work function. Thus, an OLED display device is completed. As such, by using the SGS crystallization technique, a grain boundary does not exist in the channel region of the semiconductor layer, and thus an OLED display device having improved charge mobility and electrical characteristics can be provided. Further, a grain boundary does not exist in a pixel region, thereby improving electrical characteristics thereof.

FIG. 3 is a plan view of an OLED display device according to an exemplary embodiment of the present invention. Referring to FIG. 3, a data line **1** is arranged in one direction, a scan line **2** is insulated from the data line **1**, and the data line **1** and the scan line **2** cross each other. A common power voltage line **3** is insulated from the scan line **2** and disposed parallel to the data line **1**, and the common power voltage line **3** crosses the scan line **2**. A plurality of unit pixels, for example, R, G, and B unit pixels, are defined by the data line **1**, the scan line **2**, and the common power voltage line **3**.

Accordingly, in each unit pixel, data signals applied to the data line **1** in response to a signal applied to the scan line **2** are input to a driving thin film transistor **6**. A capacitor **7** accumulates charges according to a difference between a data voltage and a voltage applied to the common power line **3**, and signals by the charges accumulated in the capacitor **7** are input to the driving thin film transistor **6** through a switching thin film transistor **5**.

Then, the driving thin film transistor **6** receiving the data signal emits light by sending an electrical signal to an OLED **8** having a pixel electrode, i.e., a first electrode, an upper electrode, i.e., a second electrode, and an organic emission layer which is formed between both the electrodes.

FIGS. 4A to 4F are cross-sectional views of the OLED display device taken along line I-I' of FIG. 3. Referring to FIG. 4A, a substrate **400** is formed of plastic, conductive material, or transparent glass. In the substrate **400**, a first unit pixel region a, an interconnection region b, and a second unit pixel region c are defined. The interconnection region b is a region in which a metal interconnection is formed. The interconnection region b may be disposed in edges of respective unit pixels.

A buffer layer **410** is formed on the substrate **400**. The buffer layer **410** may be formed in a single or double layer using a silicon oxide layer and/or a silicon nitride layer, and the buffer layer **410** may be formed by a CVD or PVD technique. Here, the buffer layer **410** serves to prevent diffusion of moisture or impurities generated from the substrate **400** and to facilitate crystallization of an amorphous silicon layer by controlling a heat transmission rate during crystallization.

Subsequently, an amorphous silicon layer **420a** is formed on the entire surface of the substrate **400**. The amorphous silicon layer **420a** may be formed using a PVD technique, such as sputtering, or a CVD technique, such as PECVD or LPCVD. Also, while or after forming the amorphous silicon layer **420a**, a hydrogen concentration may be lowered by dehydrogenation.

Then, a first capping layer **430a** and a second capping layer **430b** are formed on the entire surface of the substrate **400**. The first and second capping layers **430a** and **430b** may be a silicon nitride layer into which metal catalysts formed in the subsequent process are diffused by annealing, or a combination of a silicon nitride layer and a silicon oxide layer. Also, the first and second capping layers **430a** and **430b** may be formed using a CVD or PVD technique, wherein the capping layer may be formed to a thickness of 1 to 2000 Å.

Referring to FIG. 4B, a partial region of the second capping layer **430b**, that is, a partial region of the second capping layer **430b** on a region in which the amorphous silicon layer **420a** will be formed into a first capacitor electrode, is etched to form openings **435a** and **435b**. Here, the openings **435a** and **435b** expose a partial region of the first capping layer **430a** by etching the second capping layer **430b** in regions symmetrically disposed about the interconnection region b. The grain boundary as described above is formed in the interconnection region b in the subsequent SGS crystallization process.

A metal catalyst layer **440** is formed by depositing a metal catalyst on the entire surface of the substrate **400**. Here, the metal catalyst may be one selected from the group consisting of Ni, Pd, Ti, Ag, Au, Al, Sn, Sb, Cu, Co, Mo, Tb, Ru, Rh, Cd and Pt, and preferably Ni. Here, the metal catalyst layer **440** is formed at a surface density of 10^{11} to 10^{15} atoms/cm². While, if the surface density is less than 10^{11} atoms/cm², the amorphous silicon layer may be difficult to crystallize into a polycrystalline silicon layer due to a low amount of seeds, that is, crystallization cores; and if the surface density is more than 10^{15} atoms/cm², a crystal grain of the polycrystalline silicon layer may become smaller due to a large amount of the metal catalysts diffused into the amorphous silicon layer.

Subsequently, the substrate **400** having the buffer layer **410**, the amorphous silicon layer **420a**, the first capping layer **430a**, the second capping layer **430b**, and the metal catalyst layer **440** is annealed. During annealing, some of the metal catalysts in the metal catalyst layer **440** move to the amorphous silicon layer **420a**. That is, only a very small amount of the metal catalysts diffuse into the amorphous silicon layer **420a** through the first capping layer **430a** by annealing, and most of the metal catalysts cannot reach the amorphous silicon layer **420a** or cannot pass through the first and second capping layers **430a** and **430b**.

Thus, the amount of the metal catalysts reaching the amorphous silicon layer **420a** is determined by diffusion blocking abilities of the first and second capping layers **430a** and **430b**, wherein the diffusion blocking ability of the first and second capping layers **430a** and **430b** may be related to the thickness of the first and second capping layers **430a** and **430b**. That is, as the thickness of the first and second capping layers **430a** and **430b** increases, the diffusion amount decreases, thereby the grain becomes larger, and as the thickness of the first and second capping layers **430a** and **430b** decreases, the diffusion amount increases, thereby the grain becomes smaller.

Here, the annealing process is performed at a temperature of 200 to 900° C. for several seconds to hours in order to diffuse the metal catalysts by one or a combination of a furnace process, an RTA process, an UV process, and a laser process.

Accordingly, the metal catalysts diffused into the amorphous silicon layer **420a** through the first capping layer **430a** are combined with silicon of the amorphous silicon layer to form metal silicide, and the metal silicide forms a seed, i.e., a core of crystallization, thereby crystallizing the amorphous silicon layer into the polycrystalline silicon layer. As such, the first and second capping layers **430a** and **430b** are formed on the amorphous silicon layer, and the metal catalyst layer is formed on the first and second capping layers **430a** and **430b** and annealed to diffuse the metal catalysts therethrough, thereby crystallizing the amorphous silicon layer into the polycrystalline layer, which is called an SGS crystallization technique.

That is, region A illustrated in FIG. 4B becomes an SGS crystallization seed region A having a seed formed of the metal silicide by combining the metal catalysts diffused into the amorphous silicon layer **420a** through the first capping layer **430a** with the silicon, and region B becomes an SGS crystallization growth region B, which does not include the seed because the metal catalysts cannot diffuse into the amorphous silicon layer **420a** due to the first and second capping layers **430a** and **430b**. The SGS crystallization growth region B is crystallized into the polycrystalline silicon layer by growing crystals from the SGS crystallization seed region A.

More specifically, region A, i.e., the SGS crystallization seed region A, is formed through the openings **435a** and **435b** of the first and second unit pixel regions a and b, and region B, i.e., a peripheral region of the SGS crystallization seed region, becomes the SGS crystallization growth region B by growing the crystals from the SGS crystallization seed region A to be crystallized into the polycrystalline silicon layer. Thus, SGS crystals of the first and second unit pixel regions are faced in the interconnection region b in which a metal interconnection will be formed, thereby creating a grain boundary. As a result, since the grain boundary is formed in the interconnection region b, the uniform polycrystalline silicon layer, which does not have a grain boundary, is formed in each unit pixel, and thus a semiconductor layer which does not have a grain boundary in any unit pixel may be formed.

In this embodiment according to aspects of the present invention, the SGS crystallization seed region A, that is, a region in which a first capacitor electrode will be formed, is located in the middle of each unit pixel and then crystallized. Further, when the SGS crystallization seed region A, in which the first capacitor electrode will be formed, is symmetrically disposed about the interconnection region b, the grain boundary may be formed in the interconnection region b.

Then, referring to FIG. 4C, the crystallized polycrystalline silicon layer is patterned, and semiconductor layers **420c** and **420d** and a first capacitor electrode **420e** are formed in the first unit pixel region a, and semiconductor layers **420c'** and **420d'** and first capacitor electrode **420e'** are formed in the second unit pixel region c.

The first capacitor electrodes **420e** and **420e'** preferably use the SGS crystallization seed region formed in the previous crystallization process, in which metal silicide exists, because the characteristics of the first capacitor electrodes **420e** and **420e'** become better as the first capacitor electrodes **420e** and **420e'** are closer to metal.

Also, the semiconductor layers **420c**, **420d**, **420c'**, and **420d'**, use the SGS crystallization growth region B formed in the previous crystallization process, and may be formed to have a length direction of a channel region of the semiconductor layer (i.e., the channel region of the patterned, polycrystallized amorphous silicon layer **420**) parallel to the SGS crystallization growth direction. That is, since the length directions of the channel regions of the semiconductor layers

420c, **420d**, **420c'**, and **420d'** are formed parallel to the SGS crystallization growth direction, the channel regions without grain boundaries may be formed, thereby improving electrical characteristics of the device without deterioration of charge mobility.

After that, referring to FIG. 4D, a gate insulating layer **450** is formed on the entire surface of the substrate **400**. The gate insulating layer **450** may be formed of a silicon oxide layer, a silicon nitride layer, or a combination thereof. The gate insulating layer **450** is disposed between the semiconductor layers **420c**, **420d**, **420c'**, **420d'** and gate electrodes to be formed layer; therefore, the gate insulating layer **450** insulate the semiconductor layers **420c**, **420d**, **420c'**, **420d'** from the gate electrodes. Also, The gate insulating layer **450** may be disposed between the first capacitor electrode **420e** and **420e'** and a second capacitor electrode to be formed later, thereby controlling the thickness of the gate insulating layer **450** to control capacitance of a capacitor. Here, the capacitance is inversely proportional to the thickness of the insulating layer of the capacitor, and thus the gate insulating layer **450** may be formed thinly.

Then, a photoresist is coated on the substrate **400** by, for example, spin coating, and exposed and developed, thereby forming photoresist patterns **451c**, **451c'**, **451c'** and **451c'** on partial regions corresponding to the semiconductor layers **420c**, **420d**, **420c'**, and **420d'**, respectively. It may be preferable that the photoresist patterns are formed on regions corresponding to the middle of the semiconductor layers **420c**, **420d**, **420c'**, and **420d'**, respectively, because the regions corresponding to the photoresist patterns **451c**, **451c'**, **451c'**, and **451c'** will be defined as channel regions of the semiconductor layers **420c**, **420d**, **420c'**, and **420d'** later.

Subsequently, an impurity implantation process is performed on the entire surface of the substrate **400** having the photoresist patterns **451c**, **451c'**, **451c'** and **451c'** as masks. As a result, source, drain, and channel regions are defined in the semiconductor layers **420c**, **420d**, **420c'**, and **420d'**. Here, in each semiconductor layer **420c**, **420d**, **420c'**, or **420d'**, the regions implanted with impurities are defined as the source and drain regions, and the regions not implanted with impurities protected by the photoresist pattern are defined as the channel regions. The first capacitor electrodes **420e** and **420e'** are also implanted with impurities to provide conductivity thereto because the capacitor has better characteristics as the capacitor electrode is closer to a conductor.

Referring to FIG. 4E, after the impurity implantation process, the photoresist patterns **451c**, **451c'**, **451c'** and **451c'** are removed, and a conductive material which simultaneously forms a gate electrode and a second capacitor electrode is deposited on the entire surface of the substrate **400**. Then, the conductive material is patterned to correspond to partial regions of the semiconductor layers **420c**, **420d**, **420c'**, and **420d'** and the first capacitor electrode to form gate electrodes **460a**, **460b**, **460a'**, and **460b'**, and second capacitor electrodes **460c** and **460c'**, and thus the capacitor is completed. Here, the second capacitor electrodes **460c** and **460c'** may be formed of the same material as the gate electrode or the source and drain electrodes. Further, a metal interconnection **465** may be formed in the interconnection region b on the gate insulating layer **450** to be covered by the interlayer insulating layer **470**.

Then, after the interlayer insulating layer **470** is formed on the entire surface of the substrate **400**, and partial regions of the interlayer insulating layer **470** and the gate insulating layer **450** are etched, thereby exposing surfaces of the source and drain regions of the semiconductor layers **420c**, **420d**, **420c'**, and **420d'**, and source and drain electrode materials are deposited and then patterned, thereby forming source and

drain electrodes **471a**, **472a**, **471b**, **472b**, **471a'**, **472a'**, **471b'**, and **472b'**. Finally, the thin film transistors and the capacitors are completed.

As such, the channel region of the semiconductor layer does not have a grain boundary due to the SGS crystallization technique, which results in improvement of the charge mobility and electrical characteristics of the thin film transistor. The thin film transistor according to the exemplary embodiments of the present invention is not limited to an OLED display device to be described later, and may be applied to other display devices, such as LCD devices.

Then, referring to FIG. 4F, a planarization layer **480** is formed on the entire surface of the substrate **400**. The planarization layer **480** may be an organic layer, an inorganic layer, or a combination thereof. When the planarization layer **480** is an inorganic layer, Spin On Glass (SOG) may be used, when the planarization layer **480** is an organic layer, acryl series resin, polyimide series resin, or BCB may be used. Also, the planarization layer **480** includes holes **481a** and **481b** each exposing one of the source and drain electrodes **471a**, **472a**, **471b**, **472b**, **471a'**, **472a'**, **471b'**, and **472b'**.

First electrodes **490a** and **490b** are formed on the planarization layer **480**. The first electrodes **490a** and **490b** are in contact with the exposed source and drain electrodes (**472b** and **472b'** in FIG. 4F) through the holes **481a** and **481b**, respectively, and extend onto the planarization layer **480**. The first electrodes **490a** and **490b** may be formed of ITO or IZO.

Then, a pixel defining layer **500** is formed on the entire surface of the substrate **400** including the first electrodes **490a** and **490b**, which is formed to have a sufficient thickness cover the first electrodes **490a** and **490b**. The pixel defining layer **500** may be an organic or inorganic layer, and preferably an organic layer. More preferably, the pixel defining layer **500** may be formed of one selected from the group consisting of BCB, acryl series polymer, and polyimide. The pixel defining layer **500** has excellent flowability, and thus may be evenly formed on the entire surface of the substrate **400**. The pixel defining layer **500** is etched to form openings exposing the first electrodes **490a** and **490b**.

Subsequently, organic layers **510a** and **510b** are formed on the first electrodes **490a** and **490b** exposed through the openings. The organic layers **510a** and **510b** include at least an emission layer, and further include at least one of a hole injection layer, a hole transport layer, an electron transport layer, and an electron injection layer. The organic layers **510a** and **510b** may include R, G and B emission layers to realize full colors. The organic layers **510a** and **510b** may be formed of an organic material displaying white, or may be emission layers realizing white by stacking R, G and B emission layers.

Then, a second electrode **520** is formed on the entire surface of the substrate **400**. The second electrode **520** may be formed as a transmissive electrode and may be formed of a low work function material such as Mg, Ag, Al, Ca, or alloys thereof. Thus, the OLED display device according to aspects of the present invention is completed.

As such, by using the SGS crystallization technique, a grain boundary does not exist in the channel region of the semiconductor layer, which may result in improved charge mobility and electrical characteristics. Also, the SGS crystallization seed regions are symmetrically disposed about the interconnection region, thereby the grain boundary does not exist in each unit pixel region, and thus the semiconductor layer may be formed in any region without limitation. Consequently, an OLED display device and a method of fabricating the same according to aspects of the present invention can

uniformly control electrical characteristics of a thin film transistor, and enhance luminous efficiency of the OLED display device.

Although a few embodiments of the present invention have been shown and described, it would be appreciated by those skilled in the art that changes may be made in this embodiment without departing from the principles and spirit of the invention, the scope of which is defined in the claims and their equivalents.

What is claimed is:

1. A flat panel display device, comprising:
a thin film transistor disposed on a substrate, the thin film transistor comprising:
a semiconductor layer formed in a super grain silicon (SGS) crystallization growth region of a crystalline silicon layer disposed on the substrate and having source and drain regions and a channel region,
a gate electrode formed to correspond to a partial region of the semiconductor layer,
a gate insulating layer to insulate the semiconductor layer from the gate electrode, and
source and drain electrodes electrically connected to the source and drain regions of the semiconductor layer;
a capacitor comprising:
a first capacitor electrode spaced apart from the thin film transistor on the substrate and formed in an SGS crystallization seed region of the crystalline silicon layer disposed on the substrate,
a second capacitor electrode formed on the gate insulating layer, and
the gate insulating layer to insulate the first capacitor electrode from the second capacitor electrode; and
a first electrode of a display electrically connected to one of the source or drain electrodes of the thin film transistor, wherein a grain boundary of the growth region is not disposed in the semiconductor layer.
2. The device of claim 1, wherein the display comprises an organic light emitting diode (OLED) display electrically connected to the thin film transistor, the OLED including the first electrode electrically connected to one of the source or drain electrodes, an organic layer disposed on the first electrode and having an emission layer, and a second electrode disposed on the organic layer.
3. The device of claim 1, wherein a length direction of the channel region of the semiconductor layer is parallel to an SGS crystallization growth direction of the SGS crystallization growth region.
4. The device of claim 1, wherein a seed to promote growth of crystals in the SGS crystallization is formed by a metal catalyst.
5. The device of claim 4, wherein the metal catalyst is one selected from the group consisting of nickel (Ni), palladium (Pd), titanium (Ti), silver (Ag), gold (Au), aluminum (Al), tin (Sn), antimony (Sb), copper (Cu), cobalt (Co), molybdenum (Mo), terbium (Tb), ruthenium (Ru), rhodium (Rh), cadmium (Cd), and platinum (Pt).
6. The device of claim 1, wherein the first capacitor electrode further comprises metal silicide.

7. The device of claim 1, wherein the second capacitor electrode is formed of the same material as the gate electrode or the source and drain electrodes.

8. A flat panel display device, comprising:
a substrate having a first unit pixel region, a second unit pixel region, and an interconnection region disposed therebetween;
thin film transistors comprising:
semiconductor layers disposed on the first and second unit pixel regions of the substrate, and including source, drain, and channel regions formed in super grain silicon (SGS) crystallization growth regions of a crystalline silicon layer disposed on the substrate,
gate electrodes formed to correspond to partial regions of the semiconductor layers,
a gate insulating layer to insulate the semiconductor layers from the gate electrodes, and
source and drain electrodes electrically connected respectively to the source and drain regions of the semiconductor layer;
capacitors comprising:
first capacitor electrodes disposed about the interconnection region on the first and second unit pixel regions, and formed in SGS crystallization seed regions of the crystalline silicon layer disposed on the substrate,
the gate insulating layer disposed on the first capacitor electrodes, and
second capacitor electrodes disposed on the gate insulating layer; and
first electrodes of a display electrically connected to one of the source and drain electrodes of the thin film transistors, respectively,
wherein a grain boundary is formed in the interconnection region.
9. The display device of claim 8, wherein the display comprises an organic light emitting diode (OLED) display electrically connected to the thin film transistors, the OLED including the first electrodes electrically and respectively connected to one of the source or drain electrodes of the thin film transistors, organic layers disposed on the first electrodes and each organic layer having an emission layer, and second electrodes disposed on the organic layers.
10. The device of claim 8, wherein a length direction of the channel regions of the semiconductor layer are parallel to an SGS crystallization growth direction of the SGS crystallization growth region.
11. The device of claim 8, wherein a seed to promote growth of crystals in the SGS crystallization is formed by a metal catalyst.
12. The device of claim 11, wherein the metal catalyst is one selected from the group consisting of Ni, Pd, Ti, Ag, Au, Al, Sn, Sb, Cu, Co, Mo, Tb, Ru, Rh, Cd and Pt.
13. The device of claim 8, wherein the first capacitor electrodes further comprise metal silicide.
14. The device of claim 8, wherein the second capacitor electrodes are formed of a same material as the gate electrodes or the source and drain electrodes.

* * * * *

专利名称(译)	具有均匀电特性的有机发光二极管平板显示装置及其制造方法		
公开(公告)号	US8164096	公开(公告)日	2012-04-24
申请号	US12/047619	申请日	2008-03-13
申请(专利权)人(译)	三星SDI CO. , LTD.		
当前申请(专利权)人(译)	三星DISPLAY CO. , LTD.		
[标]发明人	CHOI JONG HYUN JUN WOO SIK		
发明人	CHOI, JONG-HYUN JUN, WOO-SIK		
IPC分类号	H01L27/14		
CPC分类号	H01L27/1255 H01L27/1277 H01L21/02532 H01L21/02672 H01L27/3244		
优先权	1020070024584 2007-03-13 KR		
其他公开文献	US20080224129A1		
外部链接	Espacenet USPTO		

摘要(译)

平板显示装置，更具体地，具有均匀电特性的有机发光二极管（OLED）显示装置及其制造方法包括：薄膜晶体管，其半导体层包括源极，漏极和a沟道区域形成在超晶粒硅（SGS）结晶生长区域；在SGS结晶种子区域中形成的电容器；和电连接到薄膜晶体管的OLED。此外，硅层的沟道区的长度与SGS生长区中的生长方向平行，以改善其电特性。

